

DETAIL A  
SCALE 2 : 1

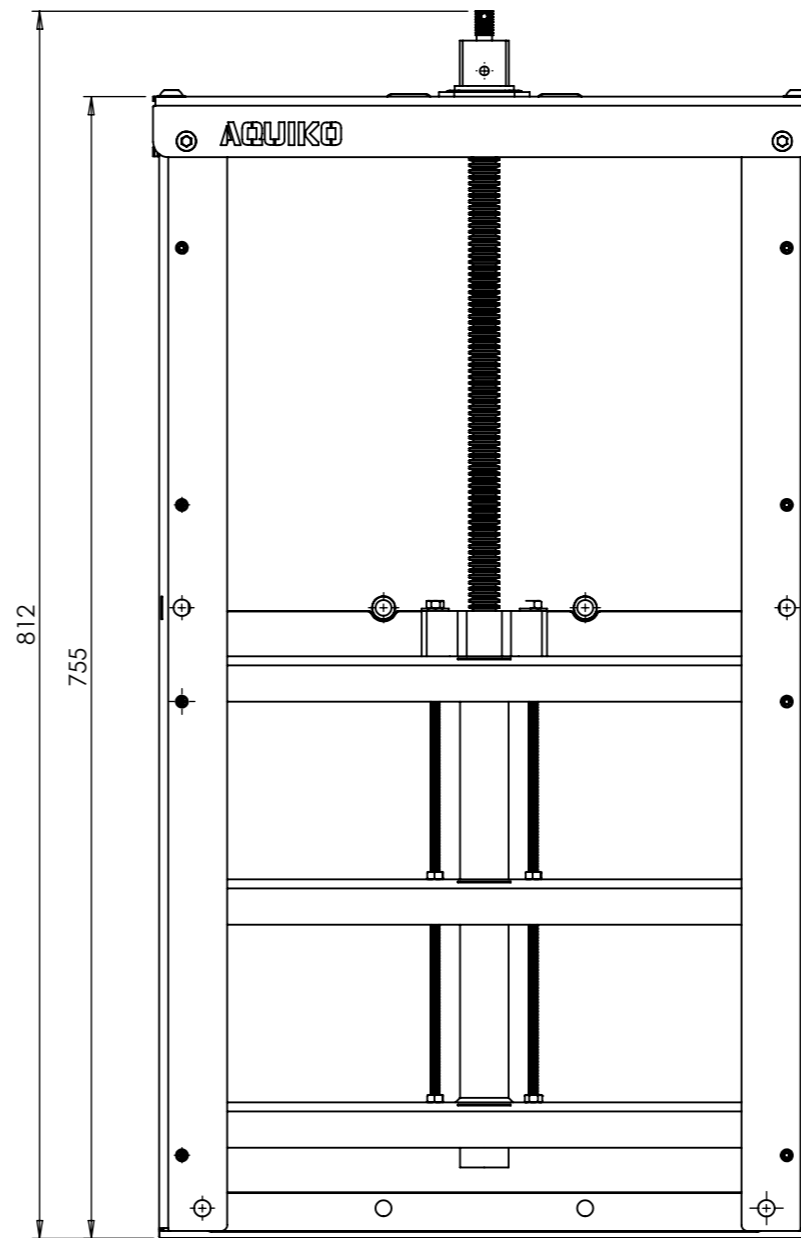

Materials:  
Plastic parts: HDPE  
Metallic Parts: Stainless Steel 316L  
Seals: EPDM Closed cell rubber  
Fitted using A4 stainless rods

	Name	Date
Received by		
Inspected by		
Assembled by		
Dispatched by		

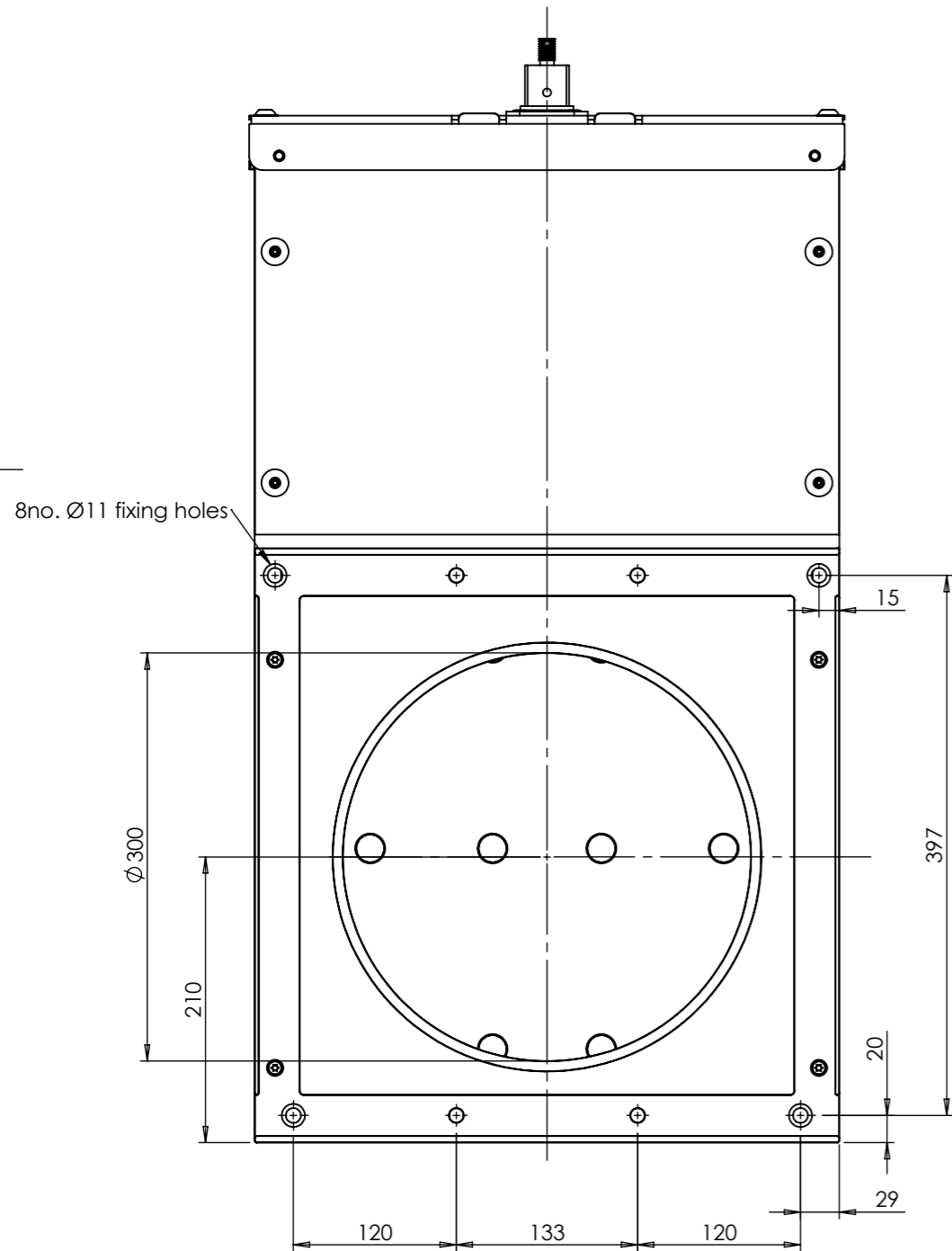

NAME	DATE
DRAWN RE	13/12/2021
CHK'D	
APP'VD	

DO NOT SCALE DRAWING  
UNLESS OTHERWISE SPECIFIED: DIMENSIONS ARE IN MILLIMETERS LINEAR, ANGULAR AND EDGE TOLERANCES ARE TO ACE DOC. DRAWING STANDARDS-2018-JC-0

TITLE:

2-300-APS-PE GA.SLDDRW

WEIGHT (kg): 22.2

SCALE 1:5

REVISION A