

DETAIL B
SCALE 1 : 10

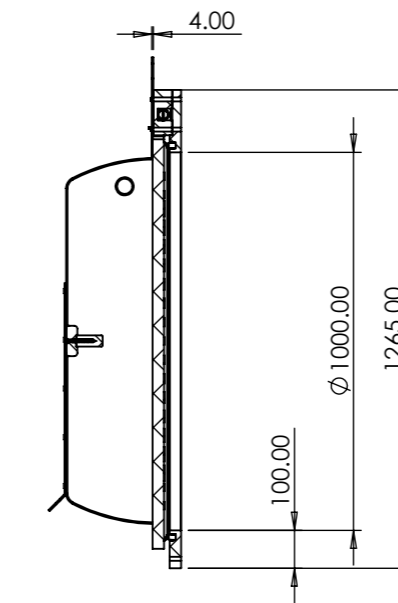

SECTION A-A

Materials:
 Flap and frame: HDPE
 Metallic Parts: Stainless Steel 316L
 Selas: EPDM Closed cell rubber
 Fitted using Resin anchors and A4 stainless rods
 Sealing surface tolerance to be 2-3mm per metre

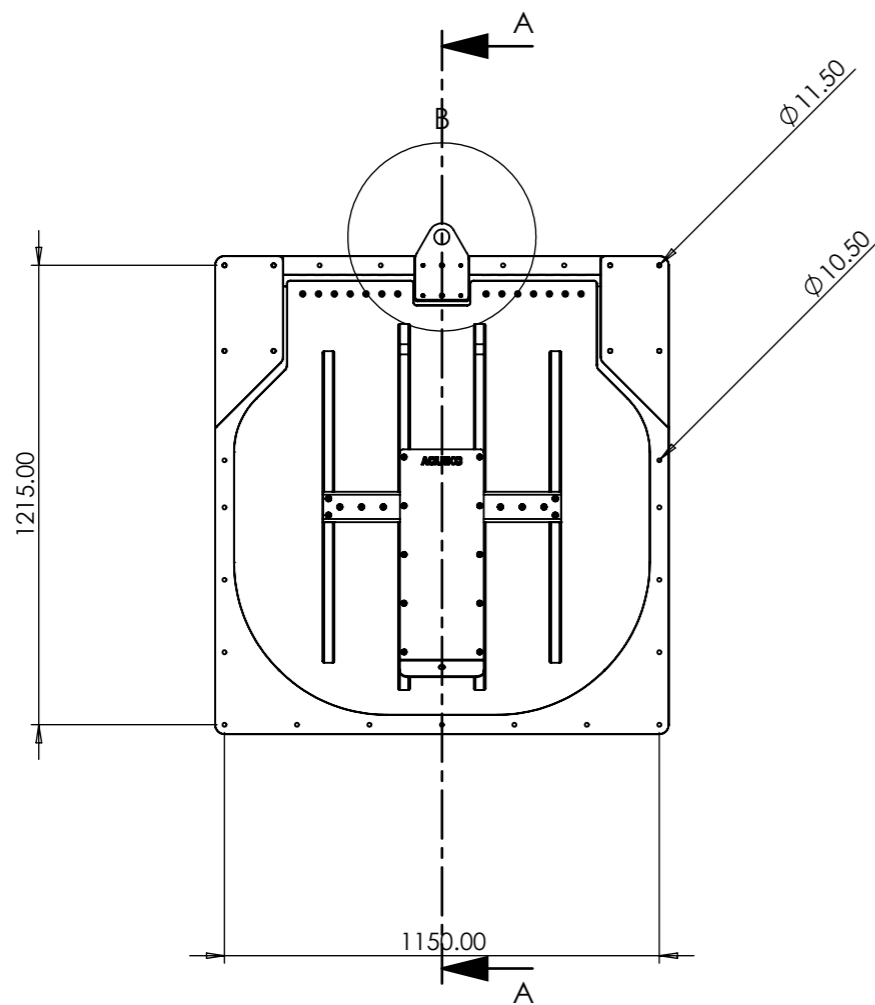
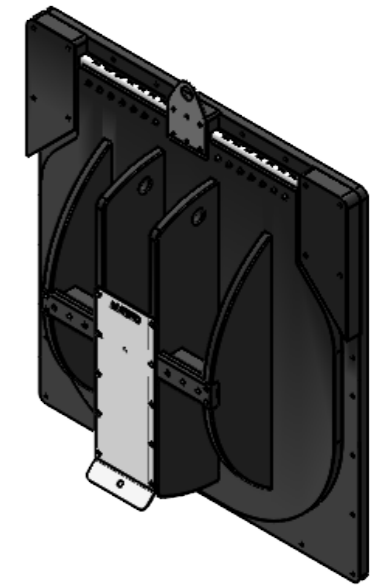

NAME	DATE
DRAWN JC	26/02/2021
CHK'D JC	07/03/2021
APP'V'D JC	07/03/2021

DO NOT SCALE DRAWING
 UNLESS OTHERWISE SPECIFIED: DIMENSIONS ARE IN MILLIMETERS LINEAR, ANGULAR AND EDGE TOLERANCES ARE TO ACE DOC. DRAWING STANDARDS-2018-JC-0

TITLE: 1000-ARF Flapvalve

1000-ARF-MED

ITEM NO.	PART NUMBER	QTY.	Material	Supplier	Processing	Drawn	Ordered	Goods in	Assembled	Packed
1	Flange	1	PE High Density							
2	Flap	1	PE High Density							
3	StiffenerA	1	1.4404 (X2CrNiMo17-12-2)							
4	Pin	1	1.4404 (X2CrNiMo17-12-2)							
5	StiffenerB	1	1.4404 (X2CrNiMo17-12-2)							
6	StiffenerC	1	1.4404 (X2CrNiMo17-12-2)							
7	Lip Seal	1	EPDM 60 Durometer							
8	StiffenerD(Right)	1	1.4404 (X2CrNiMo17-12-2)							
9	P Seal	1	EPDM 60 Durometer							
10	StiffenerD(Left)	1	1.4404 (X2CrNiMo17-12-2)							
11	StiffenerE	1	1.4404 (X2CrNiMo17-12-2)							
12	ISO 15983-FASTTO 41018.050.018-domed head blind rivet 5x18(11-13) A4	4	AISI 304							
13	ISO 15983-FASTTO 41018.050.012-domed head blind rivet 5x12(6-8) A4	3	AISI 304							
14	ISO 7380-2-TX-FASTTO 66035.100.020-button screw with flange M10x20 TX50-A4	2	1.4401 (X5CrNiMo17-12-2)							
15	ISO 7380-2-TX-FASTTO 66035.060.008-button screw with flange M6x8 TX30-A4	2	1.4401 (X5CrNiMo17-12-2)							
16	ISO 7380-2-TX-FASTTO 66035.100.045-button screw with flange M10x45 TX50-A4	4	1.4401 (X5CrNiMo17-12-2)							
17	StiffenerF	6	1.4404 (X2CrNiMo17-12-2)							
18	DIN 93166000.120.230-hex head screw M12x230	1	1.4401 (X5CrNiMo17-12-2)							
19	Bearing 008729011442	2	PA Type 6							
20	ISO 10511 FASTTO 66876.120.001-hexagon lock nut M12-A4	1	1.4401 (X5CrNiMo17-12-2)							
21	Screw-TX20-5x50 66906.050.050	1	1.4401 (X5CrNiMo17-12-2)							
22	ISO 4017-FASTTO 66012.100.030-hexagon head screw M10x30-A4	2	1.4401 (X5CrNiMo17-12-2)							

